

INSTRUCTION MANUAL

# PH 7635

## MICROPROCESSOR BASED

### pH METER - ORP METER

pH scale: 0/14,00 pH  
ORP scale: -1000/+1000 mV  
Temperature scales: 0.0/+100.0 °C  
32.0/212.0 °F

Option \_\_\_\_\_  
S/N \_\_\_\_\_  
REP N° \_\_\_\_\_



Power Supply: 85/264 Vac  
Installed Firmware: R 1.0x

## Index

1	PRODUCT PRESENTATION .....	3
1.1	Functional purpose of the unit .....	3
1.2	Functional principles .....	3
1.3	Sensors and accessories .....	3
2	GENERAL WARNINGS AND INFORMATION FOR ALL USERS .....	6
2.1	Warranty .....	6
2.2	After sales service .....	6
2.3	CE marking .....	6
2.4	Safety warnings .....	6
3	INSTRUCTION MANUAL CONTENTS .....	7
3.1	Manual revision .....	7
3.2	Symbols .....	7
3.3	How to read the instruction manual .....	8
3.3.1	Using the instrument on the plant .....	8
3.3.2	Plant maintenance staff .....	9
3.3.3	Installing the instrument in the plant .....	9
4	SPECIFICATIONS .....	10
4.1	Functional specification .....	10
4.2	Technical specifications .....	12
5	OPERATING PROCEDURES .....	16
5.1	Keyboard .....	16
5.2	Operating instructions .....	17
5.2.1	Main measuring .....	17
5.2.2	Temperature measuring .....	17
5.2.3	Set up parameters .....	18
5.2.4	Configuration parameters .....	18
5.2.5	Firmware release .....	18
5.3	Instruction for the maintenance staff .....	19
5.3.1	Preliminary operations .....	19
5.3.2	Measuring operations .....	19
5.3.3	pH calibration .....	19
5.3.4	ORP calibration .....	21
5.3.5	Set point calibration .....	22
5.3.6	Temperature calibration .....	22
5.3.7	Manual temperature compensation .....	23
5.3.8	Set-up .....	23
5.3.9	Maintenance of the unit .....	25
5.3.10	Maintenance of the sensor .....	25
5.4	Instruction for the plant engineer .....	25
5.4.1	Safety instruction .....	25
5.4.2	Configuration .....	26

6	INSTALLATION .....	28
6.1	Packing list .....	28
6.2	Unpacking.....	28
6.3	Storage and transportation .....	28
6.4	Installation of the unit.....	28
6.5	Installation of the probe .....	28
6.6	Electrical installation .....	29
6.6.1	Connecting the power .....	29
6.6.2	Connecting the electrodes or probes.....	29
6.6.3	Connecting the temperature sensor.....	30
6.6.4	Connecting the analog output .....	30
6.6.5	Connecting the pumps, solenoids and alarms.....	31
6.6.6	Connecting the logic input.....	32
7	DISPOSAL .....	32
	Warranty certificate .....	36
	Repairs .....	36
	Technical support.....	37

# 1 PRODUCT PRESENTATION

## 1.1 FUNCTIONAL PURPOSE OF THE UNIT

The basic system for monitoring pH and ORP is made of two important parts:

- the controller described in this instruction manual;
- a probe or sensor;

The instrument has the necessary electric circuits and firmware to perform the following functions:

- 1) as the proper sensor is connected, it displays the aqueous solutions' pH and ORP values;
- 2) if a Pt100 or Pt1000 temperature sensor is connected, it will display the temperature values;
- 3) it performs an automatic or manual temperature compensation for pH measures;
- 4) if dosing pumps or solenoids are connected to the specific relays, it will automatically adjust the pH and ORP values;
- 5) if the measure goes outside the low/high limit values, it will give an alarm;
- 6) it provides an analog output for recording and acquiring the pH and ORP values;
- 7) to receive an external free voltage contact that activates the alarm or the hold condition.

## 1.2 FUNCTIONAL PRINCIPLES

When measuring pH, the instrument receives a mV signal from the sensor and it displays the value in pH units; this is done according to Nernst's law and the sensor used.

When measuring ORP, the instrument receives a mV signal from the sensor and it displays the value in mV.

In both cases, it is possible to make the necessary adjustments (*Zero* and *Sensitivity*) to compensate the sensor response variations due to working conditions.

Temperature influences the solution's ionic activity and the signal provided by the sensor.

For this, in applications where the liquid temperature is different from a reference value of 20 °C, it is important to use the temperature compensation function.

In applications where there is a great variation of the temperature value, it is recommended to consider using a RTD and to use the automatic temperature function.

## 1.3 SENSORS AND ACCESSORIES

The listed articles are the most commonly used ones. They must be ordered separately.

Sensors and accessories for heavier and particular applications are also available.

Our staff is always available to help Customers selecting the most appropriate and suitable solution for their specific needs.

**Immersion probes with electrode**

- SI 161 probe with pH sensor, L= 720 mm*  
*SI 181 probe with pH sensor, L=1170 mm*  
  
*SI 262 probe with ORP electrode Au/reference, L= 720 mm*  
*SI 263 probe with ORP electrode Pt/reference, L=720 mm*

**Electrodes**

- SZ 145 pH sensor, epoxy body for normally clean liquids*  
*SZ 165 pH sensor, glass body for dirty and contaminated liquids*  
*SZ 173 pH sensor, glass body for polluted liquids*  
*SZ 195.1 pH sensor, glass body for high temperature and heavy alkaline liquids*  
*SZ 1075 antimony pH sensor ,epoxy body for liquids with HF contents*  
  
*SZ 245 ORP sensor in Au, epoxy body for cyanide treatment*  
*SZ 255 ORP sensor in Pt, epoxy body for generic use (clean liquids)*  
*SZ 265 ORP sensor in Au, glass body for cyanide treatment*  
*SZ 275 ORP sensor in Pt, glass body for generic use*  
*SZ 2055 ORP sensor in Pt, epoxy body for high temp. and liquids with HF contents*  
  
*SZ 1140 pH sensor, body in PVDF, autoclean, 3/4" NPT thread*  
*SZ 1150 pH sensor, body in PVDF, autoclean, 3/4" NPT thread, built-in Pt100*  
  
*SZ 2060 ORP sensor, body in PVDF, autoclean, 3/4" NPT thread*

**Immersion probes, holders and flow cells**

- SZ 810 immersion probe in PVC, L=210 mm*  
*SZ 820 immersion probe in PVC, L=400 mm*  
*SZ 821 immersion probe in PVDF, L=400 mm*  
*SZ 860 immersion probe in PVC, L=720 mm*  
*SZ 880 immersion probe in PVC, L=1170 mm*



- SZ 7101 sensor holder in PVC, for in-line measures up to 40° C*  
*SZ 7105 sensor holder in PVDF, for in-line measures up to 100° C*  
*SZ 7108 sensor holder in AISI 316, for in-line measures up to 110° C*



- SZ 7231 flow cell for one electrode and one temperature sensor*  
*SZ 7233 flow cell for three electrodes and one temperature sensor*

## Temperature probes

<i>SI 520</i>	<i>Pt100 probe for in-flow measures</i>
<i>SI 540</i>	<i>Pt100 probe for submersible measures</i>
<i>SP 514</i>	<i>Pt100 probe for flow cells</i>

## Accessories



<i>BC 931.2</i>	<i>watertight enclosure for 1 controller. IP65</i>
<i>BC 931.3</i>	<i>watertight enclosure for 2 controllers. IP65</i>



<i>SZ 740</i>	<i>junction box. IP65</i>
<i>SZ 911</i>	<i>stopper</i>

<i>SZ 9215</i>	<i>coax cable D=2,5 mm, L=100 m</i>
<i>SZ 947</i>	<i>coax cable for SZ 1140 and SZ 2060</i>
<i>SZ 9441</i>	<i>coax cable for SZ 1150</i>

## Standard solutions



<i>SZ 952</i>	<i>buffer solution pH=4, 250 cc</i>
<i>SZ 954</i>	<i>buffer solution pH=7, 250 cc</i>
<i>SZ 956</i>	<i>buffer solution pH= 9, 250 cc</i>
<i>SZ 961</i>	<i>ORP standard solution 220 mV, 250 cc</i>
<i>SZ 964</i>	<i>ORP standard solution 468 mV, 6x30 cc</i>

## 2 GENERAL WARNINGS AND INFORMATION FOR ALL USERS

### 2.1 WARRANTY

This product is guaranteed for all manufacturing defects.

Please take a look at the terms and conditions described on the Warranty Certificate at the end of the manual.

### 2.2 AFTER SALES SERVICE

B&C Electronics offers to all of its Customers the following services:

- a free of charge Technical Assistance over the phone for problems regarding installation, calibration and regular maintenance;
- a Repairing Service in our Carnate (Italy) headquarter for all types of damages, calibration or for a scheduled maintenance.

Please take a look at the Technical Support data sheet at the end of the manual for more details.

### 2.3 CE MARKING

This instrument is manufactured according to the following European Community directives:

- 72/23/EEC “Electrical safety – low tension” amended in 93/68/EEC
- 2004/108/CEE (previously 89/336/EEC) “Electromagnetic compatibility)

The  marking is placed on the packaging and on the S/N label of the instrument.

### 2.4 SAFETY WARNINGS

It is important to underline the fact that electronic instruments are subject to accidents. For this, it is important to take all necessary precautions to avoid damages caused by malfunctions.

All types of operations must be performed by authorized and trained staff.

The use of this controller must respect the parameters described in Charter 4.2 “Technical specification”, so to avoid potential damages and a reduction of its operating life.

### 3 INSTRUCTION MANUAL CONTENTS

This chapter describes the manual and gives suggestions to all users on how to read it and use it.

The manual is written according to the following norms:

- UNI 10893 “Instructions for use”.
- UNI 10653 “Quality of product technical documentation”.

#### 3.1 MANUAL REVISION

This chapter shortly describes the differences between previously released versions of the same manual, so to help users that are already familiar with the product.

Rev. A: First release.

#### 3.2 SYMBOLS

Throughout the manual You may find the following symbols, which are both dictated by a Norm or that are simply conventional:

<b>Symbol</b>	<b>Meaning</b>
	<p><i>Attention: pay great attention to what written next to this symbol</i></p>
<p>-----  <b>WARNINGS</b>            -----</p>	<p><i>This symbol is used to warn users that if the instructions are ignored or not correctly followed, damage to the instrument can be caused</i></p>
<b>Note</b>	<p><i>This symbol is to invite the user to pay particular attention to a specific section of the manual.</i></p>
“*”	<p><i>This symbol can be found in those chapters where there have been changes from the previous releases.</i></p>





### 3.3 HOW TO READ THE INSTRUCTION MANUAL

The manual includes all necessary information to fully comprehend the product, to install it correctly, to use it and preserving it, and finally to achieve the performances for which You have selected it and purchased it.

The manual is intended for experienced and prepared personnel, who has knowledge of electronic instrumentations and industrial plants' typical operations.

The index guides the reader through the chapters and through the contents that he wishes to know or exploit.

In particular, the first chapters narrate the general characteristics and they allow the reader to become more familiar with the product by describing its accessories and its use.

The user can then verify if he/she has the necessary know-how to use the controller.

As described in the following chapters, the instrument was designed by keeping in mind three different kinds of users: generic use (*end user*), control (*maintenance staff*), installation (*plant engineer*).

#### Note

*Maintenance staff could be more interesting in the chapters regarding:*

- users instructions;
- calibration;
- maintenance;
- warranty/repair terms and conditions.

*The plant engineer will have to read the chapters and look at the application drawings in order to:*

- verify that the technical and functional characteristics are conformed with the plants requirements;
- verify that the environmental and climatic conditions required by the instruments are respected;
- make the correct electronic connections;
- become familiar with the instrument's firmware;
- configure the instrument according to the application;
- run all of the necessary tests before starting the instrument ;
- calibrate the instrument once the sensor is connected.

#### 3.3.1 Using the instrument on the plant

For the generic use, the end user can operate with a locked keyboard (suggested mode and to be set by maintenance staff). By this, he can control the data provided without the possibility of changing the configured set points.

### 3.3.2 Plant maintenance staff

Maintenance staff can select the operating values, by setting the desired parameters of the “set up” menu and after inserting the password. The user’s access to calibration, set point and alarm settings can also be enable.

The location of this set parameters can be seen in the right column of the Technical Specifications table (Chapter 4.2) and they are identified by a letter “S” followed by a number.

The operations that need to be done during the start-up and the periodical tests are the following:

- to allow only the visualization of the measures during the normal use;
- to calibrate the sensors by means of ZERO and SENS keys;
- to set the following parameters:
  - set point 1 and 2 by means of SET 1 and SET 2 keys
  - temperature value in °C or °F
  - manual temperature compensation value
  - set point 1 and 2 delay
  - min. and max. alarm value
  - alarm delay
  - activate/deactivate logic input;
- to modify password to access set up

### 3.3.3 Installing the instrument in the plant

The plant engineer, by inserting the access password and by setting and modifying the “configuration” parameters, will be able to select the necessary functions required by the plant.

The location of this set parameters can be seen in the right column of the Technical Specifications table (Chapter 4.2) and they are identified by a letter “C” followed by a number.

The operations that need to be done during the instrument installation are the following:

- pH/ORP electrode type;
- ORP scale;
- Pt100 or Pt1000 sensor;
- min. and max. function of set-point 1 and 2;
- activated/deactivated condition of alarm relay;
- 0/20 mA or 4/20 mA output range;
- hold/alarm function for logic input;
- password to access configuration.

## 4 SPECIFICATIONS

### 4.1 FUNCTIONAL SPECIFICATION

#### Display

The instrument has a 7 segments and 4 digits LED display. The display shows the measures vales and the messages to the operator.

In particular, the messages scroll on the display and they are preceded by the corresponding number of the Technical Specifications tables (Chapter 4.2).

After a 3' stand-by, the display goes back to showing the main measure.

#### Keyboard

The instrument has 8 keys, which allow to access all of available functions.

The upper keys are for zero and sensitivity calibration of pH and ORP electrodes and to confirm the set points value. All of this functions can be then protected by means of password.

The other keys will be described in the following chapters.

#### Input

The controller can measure the main parameter and the temperature.

The measured parameter is indicated by the Led positioned to the right of the display.

The pH can be measure by means of glass or antimony electrodes, while the ORP can me measure in three ranges: positive, negative, full range (negative + positive).

The temperature value, in °C or °F, can be measured with a Pt100 or Pt1000 temperature sensor; which according to the distance between sensor and controller can have 2 or 3 wires.

#### Temperature compensation

The instrument shows the temperature value. When measuring the pH, the controller is capable of manually or automatically compensate the temperature.

In case the temperature sensor is absent or it is malfunctioning, the controller goes automatically in manual compensation and it will show the value of compensation temperature.

#### Set-points

The instrument has two independent set-points which can be programmed across the whole scale to activate the correspondent relay contacts (SPST)..

When a relay is activated the corresponding Led, placed to the left side of the display, will light up. During the phase of activated delay, the LED will flash.

Thanks to the specific front panel keys SET 1 and SET 2 , setting the set point value is very simple. A password can be set in order to avoid that other users may change the settings.

For each relay, it is possible to select:

- min/max function;
- delay.

### Alarm

The instrument has an alarm relay, which contact are SPDT type.

The alarm condition can be configured for:

- higher or lower values of pH and ORP compared to the set ones;
- logic input signal coming from an external device (if this function is activated);

The alarm status can be seen on the LED marked ALM placed to the left of the display.

During the phase of activated delay, the LED will flash.

The operator can set the activated/deactivated (Act/Dea) status of relay corresponding to the alarm condition and the delay function.

### Analog output

The instrument has an isolated analog output to send the measure value. The output can be programmed 0/20 mA or 4/20 mA and it is displayed by the main measure.

The galvanic isolated output allows the controller to communicate with a PLC or with a recorder and it does not need an external power supply.

### Logic input

The instrument is equipped with a logic input to connect to external dry contacts.

The logic input function can be activated or deactivated from the set up menu.

The input function can be selected Hold/Alarm, which features are described in table 6.0 of Chapter 4.2 “Technical specifications”, and it is selected in the configuration menu.

### Universal power supply

The instrument can operate with an 85/264 Vac power supply.

### Power supply option 9/36 Vdc or 24 Vac

By installing this option, the instrument can be used with a 9/36 Vdc or 24 Vac power supply.

### Instrument set up

The instrument has the set up menu protected by a specific password.

In the menu, it is possible to deactivate the functions of sensors calibration, set points values and parameters changing, alarm and logic input parameters changing.

### Instrument configuration

The instrument has a configuration menu protected by a specific password. In the menu, it is possible to select the pH/ORP and temperature sensors, to select the min/max (Lo/Hi) set point functions, the alarm relay activation type (Act/Dea), the analog output range and the logic input function.

## 4.2 TECHNICAL SPECIFICATIONS

The display number is next to the factory values in the following tables.

SETUP parameters are indicated by : "S x.y"

CONFIGURATION parameters are indicated by: "C x.y"

x=table section y=sequence 1..2..3..4..etc.

Underlined words in the tables correspond to scrolling display messages.

1.0	MAIN MEASURE			Factory value	Display
TYPE OF MEASURE					
<u>PH/O.r.P.</u>				<u>PH</u>	C1.1
TYPE OF SENSOR					
pH measure:					
Glass pH(bulb)/Antimony pH		<u>(buLb/Ant.)</u>		<u>buLb</u>	C1.2
Electrode: Glass pH(bulb):					
Slope:		59.16 mV/pH 25 °C			
mV a 7.00 pH:		0.0			
Zero:		+/- 2 pH		0.00 pH	1.1
Sens:		80%/110%		100%	1.2
Electrode: Antimony pH:					
Slope:		50 mV/pH 25 °C			
mV a 7.00 pH:		-325			
Zero:		+/- 2 pH		0.00 pH	1.1
Sens:		70%/140%		100%	1.2
ORP measure :					
Electrode: ORP					
Zero:		+/- 100 mV		0 mV	1.1
Sens:		80%/110%		100 %	1.2
INPUT SCALE					
pH scale:		0.00/14.00 pH			
Resolution:		0.01 pH			
Under range:		-1.00 pH			
Over range:		15.00 pH			
ORP scale		<u>FULL</u>	<u>nEG.</u>	<u>POS.</u>	<u>FULL</u>
ORP scale		-1000/1000 mV	0/-1000 mV	0/1000 mV	C1.2
Resolution:		1 mV	1 mV	1 mV	
Under range:		-1100 mV	-1100 mV	-100 mV	
Over range:		1100 mV	100 mV	1100 mV	

2.0	SECONDARY MEASURE	Factory value	Display
TYPE OF MEASURE			
Temperature			
Input:	RTD <u>Pt100</u> / <u>Pt1000</u>	<u>Pt100</u>	C2.1
Connection:	3 wires		
Measure unit:	<u>°C</u> / <u>°F</u>	<u>°C</u>	S2.1
Measure and compensation range:	<u>0.0/100.0°C</u> ( <u>32.0/212.0°F</u> )		
Resolution:	<u>0.1°C</u> ( <u>0.1°F</u> )		
Under range:	<u>-10.0°C</u> ( <u>14.0°F</u> )		
Over range:	<u>110.0°C</u> ( <u>230.0°F</u> )		
Zero sensitivity:	<u>+/- 2.0°C</u> ( <u>+/- 3.6°F</u> )	<u>0°C</u> ( <u>0°F</u> )	2.1
Manual temperature value:	<u>0/100°C</u> ( <u>32/212°F</u> )	<u>20°C</u> ( <u>68°F</u> )	S2.2

3.0	SET POINT	Factory value	Display
SET POINT 1			
Action: ON-OFF			
Set point (pH):	0.00/14.00 pH	0.00 pH	3.1
Hysteresis (pH):	±0.02 pH		
Set point (Rx):	-1000/1000 mV ( <u>FULL</u> )	0 mV	3.1
Set point (Rx):	-1000/0 mV ( <u>nEG.</u> )	0 mV	3.1
Set point (Rx):	0/1000 mV ( <u>POS.</u> )	0 mV	3.1
Hysteresis (Rx):	±1 mV		
Delay:	0.0/100.0 seconds	0.2 s	S3.1
Function:	<u>Hi/Lo</u> (Max/Min)	<u>Lo</u>	C3.1
Relay contacts:	SPST 220V 5A resistive		
SET POINT 2			
Action: ON-OFF			
Set point (pH):	0.00/14.00 pH	0.00 pH	3.2
Hysteresis (pH):	±0.02 pH		
Set point (Rx):	-1000/1000 mV ( <u>FULL</u> )	0 mV	3.2
Set point (Rx):	-1000/0 mV ( <u>nEG.</u> )	0 mV	3.2
Set point (Rx):	0/1000 mV ( <u>POS.</u> )	0 mV	3.2
Hysteresis (Rx):	±1 mV		
Delay:	0.0/100.0 seconds	0.2 s	S3.2
Function:	<u>Hi/Lo</u> (Max/Min)	<u>Hi</u>	C3.2
Relay contacts:	SPST 220V 5A resistive		

4.0	ALARM	Factory value	Display
	Low value (pH):	0.00/14.00 pH	0.00 pH S4.1
	High value (pH):	0.00/14.00 pH	14.00 pH S4.2
	Hysteresis (pH):	±0.02 pH	
	Low value (Rx):	-1000/1000 mV (FULL)	-1000 mV S4.1
	High value (Rx):	-1000/1000 mV (FULL)	1000 mV S4.2
	Low value (Rx):	-1000/0 mV (nEG.)	-1000 mV S4.1
	High value (Rx):	-1000/0 mV (nEG.)	0 mV S4.2
	Low value (Rx):	0/1000 mV (POS.)	0 mV S4.1
	High value (Rx):	0/1000 mV (POS.)	1000 mV S4.2
	Hysteresis (Rx):	±1 mV	
	Delay:	0.0/100.0 seconds	1.0 s S4.3
	Contact function:	<u>Act./dEA.</u>	<u>Act.</u> C4.1
	Relay contacts:	SPDT 220V 5A resistive	

5.0	ANALOG OUTPUT	Factory value	Display
	Output range:	0-20/4-20 mA	<u>0-20</u> mA C5.1
	Under/Over range (0-20):	0.00/20.50mA	
	Under/Over range (4-20):	3.50/20.50mA	
	Response time:	2.5 seconds for 98%	
	Isolation:	250 Vac	
	R max:	600 ohm	
AN EXTERNAL POWER SUPPLY IS NOT NEEDED			

6.0	LOGIC INPUT	Factory value	Display
	Logic input: activated/deactivated	(On/OFF)	<u>OFF</u> S6.1
	Logic input function:	<u>HoLd/ALAr.</u>	<u>HoLd</u> C6.1
	HOLD conditions:		
	Analog output keeps the value	(HOLD)	
	Set points keep the status	(HOLD)	
	Alarm state deactivated	(OFF)	
	ALARM conditions:		
	Analog output activated	(RUN)	
	Set points deactivated	(OFF)	
	Alarm state activated	(ON)	
	External contacts must be free voltage		

10.0	SET UP PARAMETERS	Factory value	Display	
	Password to access SETUP menu	(0/999)	0	10.1
	Calibration and set point adjustment	<u>On/OFF</u>	<u>On</u>	S1.1
	Temperature measuring unit	<u>°C/°F</u>	<u>°C</u>	S2.1
	Manual temperature	20.0°C		S2.2
	Delay set1	0.2 s		S3.1
	Delay set2	0.2 s		S3.2
	Alarm LO (low value)	0.00 pH		S4.1
	Alarm HI (high value)	14.00 pH		S4.2
	Alarm delay	1.0 s		S4.3
	Logic input	<u>On/OFF</u>	<u>OFF</u>	S6.1
	Modify password to SETUP access	0		S10.1

11.0	CONFIGURATION PARAMETERS	Factory value	Display	
	Password to access CONFIGURATION	(0/999)	0	11.1
	Type of measure	<u>pH/O.r.P</u>	<u>pH</u>	C1.1
	pH sensor	(pH) <u>buLb/Ant.</u>	<u>buLb</u>	C1.2
	ORP range	(ORP) <u>FULL/nEG./POS.</u>	<u>FULL</u>	C1.2
	Temperature sensor	<u>Pt100/Pt1000</u>	<u>Pt100</u>	C2.1
	Set point 1 function	<u>Lo/Hi</u>	<u>Lo</u>	C3.1
	Set point 2 function	<u>Lo/Hi</u>	<u>Hi</u>	C3.2
	Alarm relay status	<u>Act./dEA.</u>	<u>Act.</u>	C4.1
	Analog output range	<u>0-20/4-20 mA</u>	<u>0-20 mA</u>	C5.1
	Logic Input function	<u>HoLd/ALAR.</u>	<u>HoLd</u>	C6.1
	Modify password to CONFIGURATION access	0		C11.1

### GENERAL SPECIFICATIONS

Display: LED 7 segments and 4 digits

Led indicators:

- set1 and set2 relay status
- alarm status
- logic input contact status
- measuring unit pH
- measuring unit mV

Operating temperature: 0/50°C

Humidity: 95% without condensation

Power supply: 85/264 Vac 50/60 Hz

Isolation: 4000 Vdc (2350 Vac) between primary and secondary (IEC 348)

Power consumption: 6 VA max.

Terminal blocks: extractable

Weight: 450 g

Dimensions: 96 x 96 x 104 mm including frame.

Dimensions (internal to switch board): 90 x 90 x 95 mm



## 5 OPERATING PROCEDURES

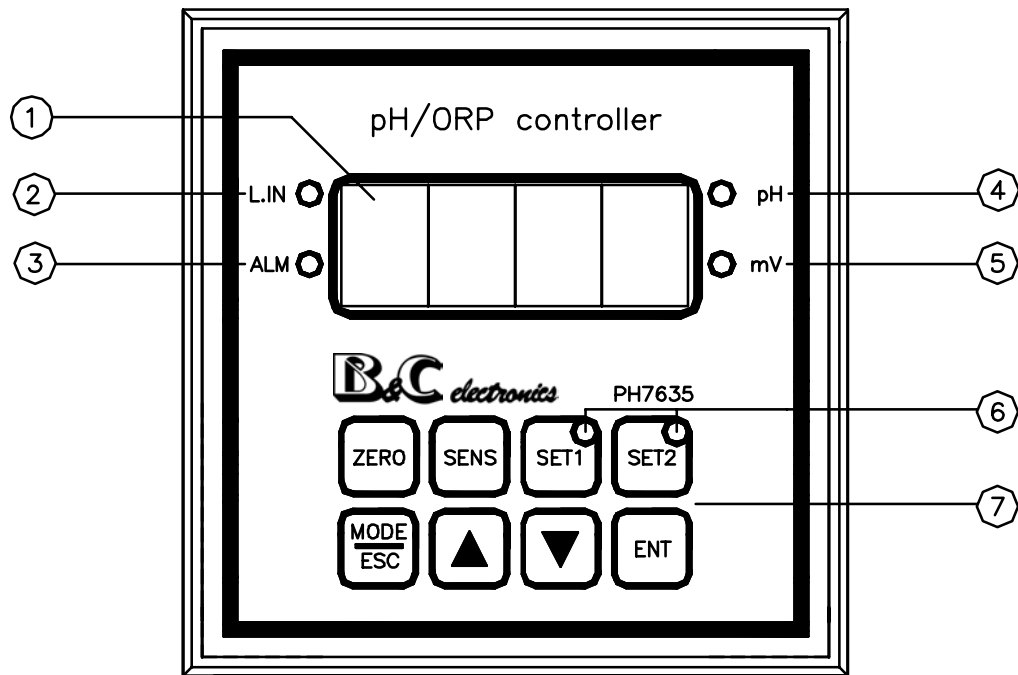

- |                                      |                              |
|--------------------------------------|------------------------------|
| 1. Values and messages display       | 4. Selected measure (pH)     |
| 2. Logic input contact visualization | 5. Selected measure (ORP)    |
| 3. Active alarm visualization        | 6. Set point relay activated |
|                                      | 7. Keyboard                  |

Fig. 1

### 5.1 KEYBOARD

 ZERO "Zero"	Starts zero calibration	 MODE ESC "Mode - Esc"	- Visualizes instrument functions - Exit without changing the values
 SENS "Sens"	Starts sensitivity calibration	 "Up"	- Increase the values - Changes the options
 SET1 "Set1"	Starts set point 1 calibration	 "Down"	- Decrease the values - Changes the options
 SET2 "Set2"	Starts set point 2 calibration	 ENT "Enter"	- Enter the new values - Starts the visualized function

## 5.2 OPERATING INSTRUCTIONS

### 5.2.1 Main measuring

The display shows the main measure values as selected in the configuration menu.

#### *pH measuring*

The front panel LED is lit according to the selected measure (pH).

Display 1.0



#### *ORP measuring*

The front panel LED is lit according to the selected measure (mV).

Display 1.0

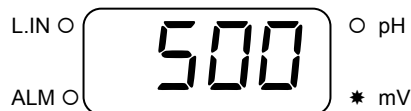

If the measuring value is under range/over range, the following messages will appear:

`- o. r. -` and `- u. r. -`.

From this display 1.0 it is possible to start the sensors calibration procedure, the set points setting (if those functions have been enabled in the set up menu).



by pressing the key, the LED 4 or 5 on the front panel are switched off and the analog output range and the expected current on the load are displayed.

`out 0-20 mA 10.00` or `out 4-20 mA 10.00`

### 5.2.2 Temperature measuring



By pressing the key from the 1.0 display, the unit will show the message `(°C °F)`, if the RTD is not connected the message `NaN`, and the temperature value (actual value or the manual value selected in the display S2.2).

Display 2.0

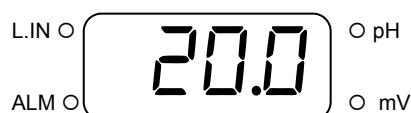

From this display it is possible the access to the calibration procedure of the temperature probe if this function is enabled by the operator.

### 5.2.3 Set up parameters

The set up parameter changing can be enabled/disabled by the operator.



By pressing two times the key from the 1.0 display, the unit will show the message **SEt-UP PrESS Ent** and it is possible to access to the menu reserved to maintenance staff (set-up)

Display 10.0

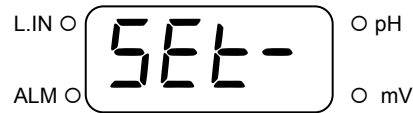

### 5.2.4 Configuration parameters



By pressing three times the key from the 1.0 display, the unit will show the message **CONF i.G. PrESS Ent** and it is possible to access to the menu reserved to the plant engineer (configuration)

Display 11.0



### 5.2.5 Firmware release



By pressing four times the key from the 1.0 display, the unit will show the message **PH7635 r 1.00** (it shows the unit p/n and the release of the firmware installed in the unit).

Display 12.0



By pressing the key, the unit turn back to the main display.

## 5.3 INSTRUCTION FOR THE MAINTENANCE STAFF

### 5.3.1 Preliminary operations

All the functioning operations must be done with sensor or simulator connected to the unit.

If the simulator is not available it is possible to install a jumper on the input terminals of the pH/ORP electrodes, in order to simulate pH=7 or mV=0 values.

Verify if the configuration, the set point and the alarm parameter are suitable for the current application.

Follow the procedures described in the chapter 5.3.8 to verify the parameters without modifying the values.

The display, LED and keys in the front panel allow the operator to perform the preliminary check.

A lit display indicates that the unit is powered and the power circuits work correctly.

### 5.3.2 Measuring operations

In order to correctly operate the system, remember to verify the following:

- sensors are installed and in contact with the liquid;
- analog output if necessary;
- eventual actuation of the relays 1 and 2;
- alarm relay if necessary;
- logic input if necessary;
- power supply and ground;

Power the unit and read the pH/ORP value of the liquid and the status of the set points.

If sensors and probes are connected correctly as described in chapter 6 "Installation", the system will operate properly and it will only need the calibration and the set point/ alarm values setting.

### 5.3.3 pH calibration

Before performing the calibration through the buffer solutions, verify that the glass membrane of the sensor has been kept wet while in storage.

If the protective reservoir is empty and the electrode is dry, dip the electrode in a buffer solution or tap water (do not use deionized water) for three hours before proceeding.

You may also follow the instruction of the sensor's manufacturer.

In order to perform the pH electrode calibration, you may also use B&C Electronics buffer solutions.

Dip the sensor into the buffer solution pH=7 (SZ 954) to perform the first point calibration (zero calibration).



By pressing the key, the unit will show the message `ZERO CAL`, followed by the actual pH value, or `CAL. OFF` if the calibration function has been disabled into the set up menu ( display S1.1).



or press the keys to change the value according to the buffer solution value



press to confirm and to end the calibration.

`UPDATE` or `ZERO Error` messages will appear.

The message of error must be confirmed if the calibration has not been performed.

Dip the sensor into the buffer solution pH=4 (SZ 952) or pH=9 (SZ 956) to perform the second point calibration (sensitivity calibration).



By pressing the key, the unit will show the message `SENS. CAL`, followed by the actual pH value, or `CAL. OFF` if the calibration function has been disabled into the set up menu ( display S1.1).



or press the keys to change the value according to the buffer solution value



press to confirm and to end the calibration

`UPDATE` or `SENS. Error` messages will appear.

The message of error must be confirmed if the calibration has not been performed.

If the operator needs to turn to the factory calibration of the zero or the sensitivity



press the three keys together instead of using the   keys

We suggest to calibrate the second point with buffer pH=4 if the meter will operate in acidic range, and with the buffer pH=9 if the meter will operate in the alkaline range.

It is possible to perform the calibration by using the buffer solutions pH=4 and pH=9.

We suggest to rinse the electrode in tap water after each dipping in the buffer solution, in order to avoid their mixing and pollution.

In many applications it is enough to frequently perform only the zero calibration by using the buffer close to the measuring value in the process, and the zero/sensitivity calibration periodically.

After the calibration, the operator will have to check the pH value of the solution.

If the value is not considered correct, check the following:

- the buffer solution has a value not corresponding to the nominal one (because of pollution);
- the electrode is not working properly or the installation is not suitable;
- the instrument has performed only the zero calibration and not the sensitivity calibration:

The error messages during the calibration inform the operator about the bad condition of the pH electrode .

The zero > 2 pH, will show the message **ZERO ERROR**, to indicate the pollution of the reference electrode and the needing of replacement.

The sensitivity < 80% (70% for the antimony electrode) or > 110% (140% for the antimony), will show the message **SENS. ERROR**, to indicate the isolation loss in the connection or the need for replacing the electrode.

Temperature compensated operations need the following procedures when calibrating the meter:

- the pH value has to be considered at the working temperature of the buffer solution
- before calibrating, immerse the electrode and the RTD in the buffer solution and adjust the value after the temperature sensor has reached the thermal equilibrium.

Check periodically the calibration.

### 5.3.4 ORP calibration

The meter is delivered with a laboratory calibration by means of a Vdc generator.  
If calibration is necessary, we suggest to perform only the zero calibration.

In order to calibrate the ORP electrode, follow the two points calibration instruction by using the buffer solutions mod. SZ 961 (mV 220) and SZ 964 (mV 468).



By pressing the key, the unit will show the message **ZERO CAL**, followed by the actual ORP value, or **CAL. OFF** if the calibration function has been disabled into the set up menu ( display S1.1).



or press the keys to change the value according to the buffer solution value



press to confirm and to end the calibration

**UPDATE** message or **ZERO ERROR** will appear.

The message of error must be confirmed if the calibration has not been performed.

If it is necessary to calibrate the sensitivity, dip the sensor in the second buffer solution.



By pressing the key, the unit will show the message **SENS. CAL**, followed by the actual ORP value, or **CAL. OFF** if the calibration function has been disabled into the set up menu ( display S1.1).



or press the keys to change the value according to the buffer solution value



press to confirm and to end the calibration

**UPDATE** message or **SENS. Error** will appear.

The message of error must be confirmed if the calibration has not been performed.

If the operator needs to turn to the factory calibration of the zero or the sensitivity



press the three keys together instead of using the   keys

We suggest to rinse the electrode in tap water after each dipping in the buffer solution, in order to avoid their mixing and pollution .

Same as for the pH calibration, the error messages will inform about the need for replacing the sensor.

### 5.3.5 Set point calibration



By pressing the key, the unit will show the message

**SET1 (SET2) Hi** or **Lo** (depending on the configuration done in display C3.1 o C3.2) followed by the actual value,



or press the keys to change the value

**CAL. OFF** will appear if the calibration has been disabled in the set up display S1.1).



press to confirm and to end the calibration .



press the key to exit from the procedure without changing the data (this key allows to exit from all the procedure without changing the previous data/setting).

### 5.3.6 Temperature calibration



By pressing the key from the main display, the unit will access the temperature readout.



By pressing the key, the unit will show the message

**ZERO CAL.** followed by the actual value, or **CAL. OFF** if the calibration function has been disabled into the set up menu ( display S1.1).



or press the key to change the value



press to confirm and to end the calibration

**UPDATE** message or **ZERO Error** will appear.

The message of error must be confirmed if the calibration has not been performed.

If the operator needs to turn to the factory calibration of the zero



press the three keys together instead of using the   keys

### 5.3.7 Manual temperature compensation

If the RTD is not installed, the unit will display the manual temperature compensation value.

Refer to the chapter 5.3.8 display S2.2 in order to change the manual temperature value.

### 5.3.8 Set-up



By pressing two times the key from display 1.0, the unit will show the message **SET-UP PRESS ENT** (display 10.0).



By pressing the key the unit will require the user to insert the password (display 10.1)

**PASS ---**



or , press the key to insert the password



press to confirm the password and to enter the set up menu (if the password is not used, press

again the key ).

Into the set up menu the keys have the following functions:



or  to change values or options shown on the display



to confirm the value/option

(if value/option have been modified it will appear the message **UPDATE**)



to exit from the procedure and to turn to display 10.0 without any changing.

#### *Display S1.1: Inhibition of zero/sensitivity calibration and set point changing*

The following message will appear:

**1.1 CAL. Function** followed by the actual setting (**ON/OFF**)

#### *Display S2.1: Selection of the temperature measuring unit*

The following message will appear:

**2.1 TEMP. Unit** followed by the actual setting (**°C/°F**)



*Display S2.2: Manual temperature compensation value  
(in case the RTD is not connected to the unit)*

The following message will appear:

**2.2 ПРМ. ТЕМП.** followed by the actual setting (**°C/°F**) and the actual value.

*Display S3.1: Delay (in seconds) of the set point 1 relay*

The following message will appear:

**3.1 СЕТ 1 DELAY** followed by the actual value.

*Display S3.2: Delay (in seconds) of the set point 2 relay*

The following message will appear:

**3.2 СЕТ 2 DELAY** followed by the actual value.

*Display S4.1: Minimum alarm value*

The following message will appear:

**4.1 Lо ALARM** followed by the actual value (pH or mV is shown by the corresponding LED 4 or 5 on the front panel)

*Display S4.2: Maximum alarm value*

The following message will appear:

**4.1 H, ALARM** followed by the actual value (pH or mV is shown by the corresponding LED 4 or 5 on the front panel)

*Display S4.3: Delay (in seconds) of the alarm relay*

The following message will appear:

**4.3 ALARM DELAY** followed by the actual value.

*Display S6.1: Logic input*

The following message will appear:

**5.1 LOG IC INPUT** followed by the actual setting (**ON/OFF**)

*Display S10.1: Password for the set up menu*

The following message will appear:

`10.1 SET-UP PASS` followed by `---`

### 5.3.9 Maintenance of the unit

Quality components are used to give the controller a high reliability.

The frequency of such maintenance depends on the nature of each particular application.

As in any electronic equipment, the mechanical components such as switches, relays and connectors, are the most subject to damage.

### 5.3.10 Maintenance of the sensor

The state of the electrode's surface is critical for the normal operation of the system and should be inspected more frequently when using alkaline liquids, oil and grease containing water, and bio-applications.

Suggested methods for cleaning the electrode include chemical cleaning (except hydrofluoric acid) and washing detergents:

- remove the sensor from the holder,
- dip the sensor for 30 seconds in a 5% HCl solution or detergent in case of grease contamination,
- rinse thoroughly the sensor into deionised water,
- reinstall the sensor into the holder.

## 5.4 INSTRUCTION FOR THE PLANT ENGINEER

### 5.4.1 Safety instruction



Read the installation instruction (Chapter 6) and check the following before switching on the unit and performing the configuration:

- Check if the terminal 3 is connected to the ground;
- check if the connections are correct;
- check if connections are well fastened to the terminals;
- check if eventual protective fuses have the correct value.

---

### WARNINGS

---

*Eventual damages coming from wrong connections are not covered by warranty.*

## 5.4.2 Configuration



by pressing three times the key from display 1.0, the unit will show the message **CONF PrESS Ent** (display 11.0).



By pressing the key the unit will require the password insertion (display 11.1)

**PASS ---**



or , press the key to insert the password



press to confirm the password and to enter the configuration menu (if the password is not used, press again the key ).

Into the configuration menu the keys have the following functions:



or to change values or options shown on the displayed



to confirm the value/option (if value/option have been modified it will appear the message **UPdATE**)



to exit from the procedure and to turn to display 11.0 without any changing.

### *Display C1.1: pH/ORP selection*

The following message will appear:

**1.1 PEAR5**, followed by the actual setting (**PH/ORP**)

### *Display C1.2: Type of pH sensor (if PH 7635 is used as pHmeter)*

The following message will appear:

**1.2 PH SENSOR** followed by the actual setting (**buLb/ARt**)

### *Display C1.2: Measuring ORP range (if PH7635 is used as ORPmeter)*

The following message will appear:

**1.2 ORP. rRNGE** followed by the actual setting (**FULL/nEG/POS**)

*Display C2.1: Type of RTD (Pt100 or Pt1000)*

The following message will appear:

2.1 *TEMP. SENSOR Pt* followed by the actual setting (100/1000)

*Display C3.1: Set point 1 function (min/max)*

The following message will appear:

3.1 *SET 1 FUNCTION* followed by the actual setting (L/H)

*Display C3.2: Set point 2 function (min/max)*

The following message will appear:

3.2 *SET 2 FUNCTION* followed by the actual setting (L/H)

*Display C4.1: Alarm relay function (activated/deactivated)*

The following message will appear:

4.1 *ALARMS FUNCTION* followed by the actual setting (Act/dEA)

*Display C5.1: Range of the analog output (0/20 or 4/20 mA)*

The following message will appear:

5.1 *OUT* followed by the actual setting (0-20/4-20).

*Display C6.1: Logic contact function (hold/alarm)*

The following message will appear:

6.1 *LOGIC INPUT* followed by the actual setting (Hold/ALAR)

*Display C11.1: Password for the configuration menu*

The following message will appear:

11.1 *CONF ID. PASS* followed by the actual password ---.

## 6 INSTALLATION

### 6.1 PACKING LIST

The carton box contains:

- N° 1 the instrument with s/n label,
- N° 2 fixing clamp,
- N° 1 instruction manual.

### 6.2 UNPACKING

- 1) Remove the instruction manual.
- 2) Remove the controller from the carton box.
- 3) Remove the plastic protective envelope and keep the two fixing clamp.

### 6.3 STORAGE AND TRANSPORTATION

In case of long storage period, keep the instrument in a dry area.

In case of transportation, use the original carton box.

### 6.4 INSTALLATION OF THE UNIT

The instrument can be installed in a watertight enclosure or in a switch board.

The panel mounting must be done on a flat surface in a position protected from hits, moisture and corrosive fumes.

### 6.5 INSTALLATION OF THE PROBE

Follow the specific instruction of the submersible or in-line probes.

The submersible probes of B&C Electronics contain the sensor (electrode) and feature a plastic ring to adjust the immersion into the liquid.

The installation of the sensors by means of the B&C Electronics in-line holders SZ 7101 – SZ 7105 - SZ 7108 must be done with the sensor in vertical position.

The cable must be protected from rain, corrosive agents through a plastic tubing.

Do not interrupt the cable in order to avoid interference in the measuring.

In case of extension cable use a junction box (example SZ740) water tight and with high isolation terminals.

Keep the cable far away from power cables.

## 6.6 ELECTRICAL INSTALLATION

Refer to figure 2. or to the connections drawing on the back panel of the instrument.

The electrical installation consists of:

- 1) connecting the power supply;
- 2) connecting the electrodes or probes;
- 3) connecting the temperature sensor;
- 4) connecting the set points and alarm relays;
- 5) connecting the analog output;
- 6) connecting the logic input.

All connections to the instrument are made on detachable terminal strips located on the rear side.

The power connections are on a 10 terminals strip.

The signals connections are on a 5 terminals strip.

The analog output and logic input connections are on a 4 terminals strip.

### 6.6.1 Connecting the power



- Connect the ground to 3 terminal.
- Connect the 86/264 Vac power to 1-2 terminals

#### ----- WARNINGS -----

- *power the device by means of an isolation transformer*
- *avoid mains voltage from an auto-transformer*
- *avoid mains voltage from a branch point with heavy inductive loads*
- *separate power supply wires from signal ones*
- *control the mains voltage value before powering the unit.*

*The electronic equipment can occasionally be damaged.*

*The plant engineer must consider this event to prevent eventual damages caused by the instrument malfunctioning.*

### 6.6.2 Connecting the electrodes or probes

The connection of the electrodes is the most critical of the system.

The pH and ORP electrodes are connected to the central of the coax cable.

The reference electrodes are connected to the shield of the coax cable.

- Connect the central of the coax cable to 31 . high impedance terminal, marked HI.
- Connect the shield of the coax cable to 30 low impedance terminal marked LO

We suggest to use just the original cable from the manufacturer to connect the electrode to the unit.

-----  
**WARNINGS**  
-----

*The coax cable normally has a conductive black sheath between central and shield.  
Remove this covering in order to avoid its contact with the terminal marked HI.*

### 6.6.3 Connecting the temperature sensor

In order to display the temperature value and to effect the automatic temperature compensation on the pH measuring, it is necessary to connect the RTD sensor Pt100 or Pt1000.

If the temperature sensor is not connected, interrupted or in a short circuit, the unit will turn to the manual temperature compensation automatically.

#### Two wires connection of Pt1000 or Pt100 for short distance

Use a suitable two wires cable

- Connect the RTD to 27-28 terminals and install a jumper between 28-29 terminals.

The two wires connection of the Pt100 may require the temperature zero calibration to compensate the wires resistance effect.

#### Three wires connection of Pt100 for long distance

Use a suitable three wires cable.

- Connect the RTD lead to 27 terminal.
- Connect the RTD common lead to 28 and 29 terminal by using two separate wires.
- Do not interrupt the cable.  
Use high isolation terminals in case of cable extension.
- Keep the cable away from the power cables.
- In case of interference use a shielded cable and connect the shield to the 3 terminal.

### 6.6.4 Connecting the analog output

The instrument provides an isolated output current, proportional to the main measuring (pH/ORP) to send to an external recorder, PLC or similar devices.

- Connect (+) terminal of the recorder to the 15 terminal of the unit.
- Connect (-) terminal of the recorder to the 16 terminal of the unit.

If the output current will drive more loads, connect the devices in series.  
The total resistance must be lower than 600  $\Omega$ .

-----  
**WARNINGS**  
-----

*Do not supply any voltage to the analog output terminals to avoid damages on the output circuits.  
Connect only to passive input devices.*

### 6.6.5 Connecting the pumps, solenoids and alarms

The contacts of the control and alarm relays are available on the rear terminal strip of the instrument. The contacts are SPST type corresponding to set point 1 and set point 2 and SPDT type corresponding to the alarm function.

#### SET POINT 1

terminal 5 marked C : common contact  
terminal 4 marked NO : normal open contact

#### SET POINT 2

terminal 7 marked C : common contact  
terminal 6 marked NO : normal open contact

Power the load through an independent power supply in order to avoid interferences from inductive load. Install snubbers if necessary.

Install fuses as protection of the relays contacts in case of short circuit of the load.

Do not exceed the nominal current rate of the contacts (5 A resistive load).

At this step of the connection remember that each relay can be configured as min/max function.

The set point values can be adjusted only if the calibration has not been disabled; the delay can be adjusted in the set up menu. (see chapters 5.3.5, 5.3.8).

To modify the function min/max (Lo/Hi) of the set points see the charter 5.4.2 .

#### ALARM

terminal 9 marked C : common contact  
terminal 8 marked NO : normal open contact  
terminal 10 marked NC : normal closed contact

The alarm relay can be configured as activated/deactivated (Act/Dea) during the alarm conditions of the measuring.

The alarm condition occurs when the measuring is lower/higher than min/max selected values (see chapter 5.3.8); the delay of the relay action can be selected (see chapter 5.4.2).

If the configuration “Deactivated” (**DEA**) is selected, the relay will provide the alarm contact even when the unit is switched off or the it is not in operation.



### 6.6.6 Connecting the logic input

The dry contacts (voltage free) coming from an external device must be connected to the logic input terminals 17 – 18.

The activation and the configuration of the input logic is described in the Display S6.1 (chapter 5.3.8) and C6.1 (chapter 5.4.2).

The hold or alarm functions are described in the item 6.0 of the chapter 4.2 “Technical specifications”.

-----  
**WARNINGS**  
-----

*Do not supply any voltage to the logic input terminals to avoid damages on the circuits.*

## 7 DISPOSAL

If it shall become necessary to throw away this electronic equipment, please follow the disposal laws of your Country.

REAR PANEL CONNECTIONS  
PH 7635

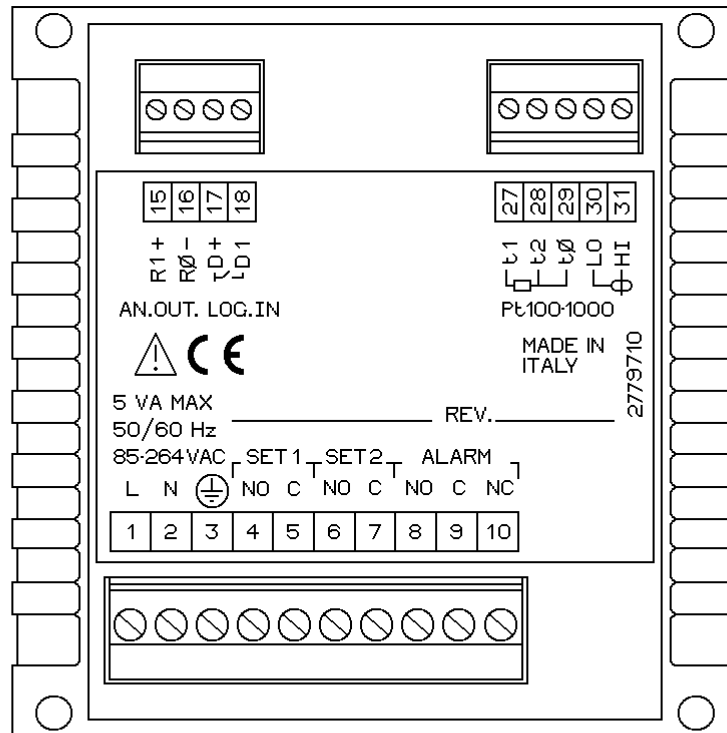

PH7635 rev.A - A4 - 1:1

1. 2	Power supply 85-264 Vac
3.	Ground
4. 5	Set point 1 N. O. contacts
6. 7	Set point 2 N. O. contacts
8. 9	Alarm N.O. contacts
9. 10	Alarm N.C. contacts
15.	Analog output (+)
16.	Analog output (-)
17. 18	Logic input
27. 28. 29	RTD Pt100/Pt1000 input
30.	Reference electrode input
31.	Glass or metal electrode input

Fig. 2

DIMENSIONS

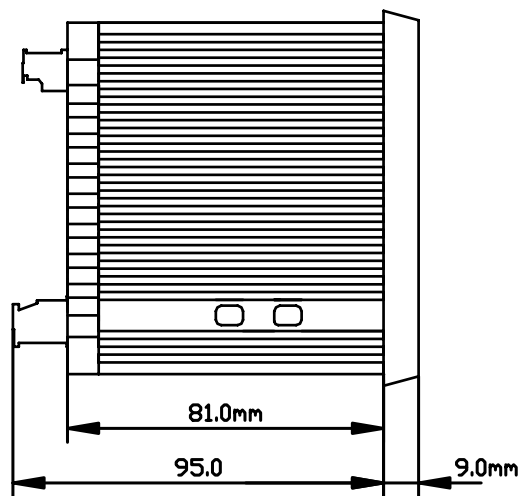
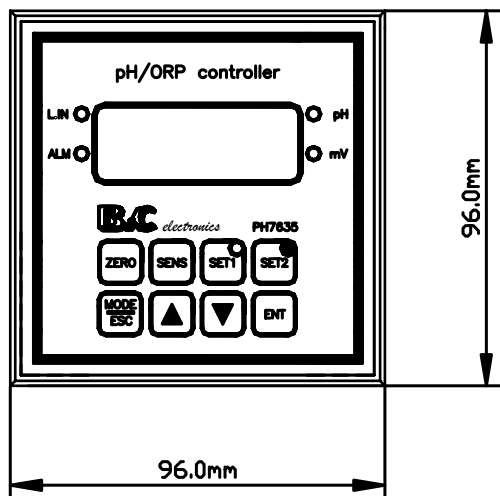

DRILL PLAN

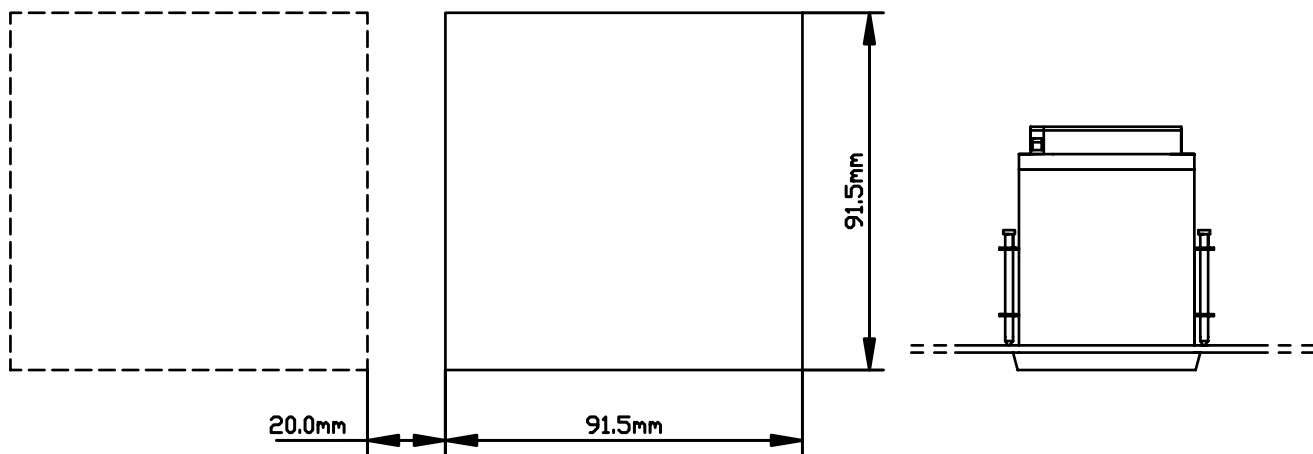

INGOMBROPH7635 - A4 -1:2

A4 -1:4

Fig. 3

# WARRANTY CERTIFICATE

- 1) Your product is covered by B&C Electronics Warranty for 5 years from the date of shipment. In order for this Warranty to be valid, the Manufacturer must determine that the instrument failed due to defective materials or workmanship.
- 2) The Warranty is void if the product has been subject to misuse and abuse, or if the damage is caused by a faulty installation or maintenance.
- 3) The Warranty includes the repair of the instrument at no charge. All repairs will be completed at the Manufacturer's facilities in Carnate, Italy.
- 4) B&C Electronics assumes no liability for consequential damages of any kind, and the buyer by accepting this equipment will assume all liability for the consequences of its use by the Customer, his employees, or others.

---

## REPAIRS

- 1) In order to efficiently solve your problem, we suggest You to ship the instrument along with the Technical Support's Data Sheet (following page) and a Repair Order.
- 2) The estimate, if requested by the Customer, is free of charge when it is followed by the Customer confirmation for repair. As opposite, if the Customer shall not decide to have the instrument repaired, he will be charged to cover labor and other expenses needed.
- 3) All instruments that need to be repaired must be shipped pre-paid to B&C Electronics. All other expenses that have not been previously discussed will be charged to Customer.
- 4) Our Sales Dept. will contact You to inform You about the estimate or to offer you an alternative, in particular when:
  - the repairing cost is too high compared to the cost of a new instrument,
  - the repairing results being technically impossible or unreliable
- 5) In order to quickly return the repaired instrument, unless differently required by the Customer, the shipment will be freight collect and through the Customer's usual forwarder.

*B&C Electronics Srl - Via per Villanova 3 - 20040 Carnate (Mi) - P.IVA 00729030965  
Tel (+39) 039 63 1721 - Fax (+39) 039 607 6099 - info@bc-electronics.it - www.bc-electronics.it*

# TECHNICAL SUPPORT

## *Data sheet*

In case of damage, we suggest You to contact our Technical Support by email or phone. If it is necessary for the instrument to be repaired, we recommend to photocopy and fill out this data sheet to be sent along with the instrument, so to help us identifying the problem and therefore accelerate the repairing process.

*ESTIMATE*

*REPAIR*

---

COMPANY NAME

---

ADDRESS

ZIP

CITY

---

REFER TO MR./MISS.

PHONE

---

MODEL

S/N

DATE

---

Please check the operator’s manual to better identify the area where the problem seems to be and please provide a brief description of the damage:

SENSOR

ANALOG OUTPUT

POWER SUPPLY

SET POINT

CALIBRATION

RELAY CONTACTS

DISPLAY

PERIODICAL MALFUNCTIONING

---

➤ *DESCRIPTION*

.....  
.....  
.....  
.....  
.....  
.....  
.....  
.....  
.....